

CYRUS

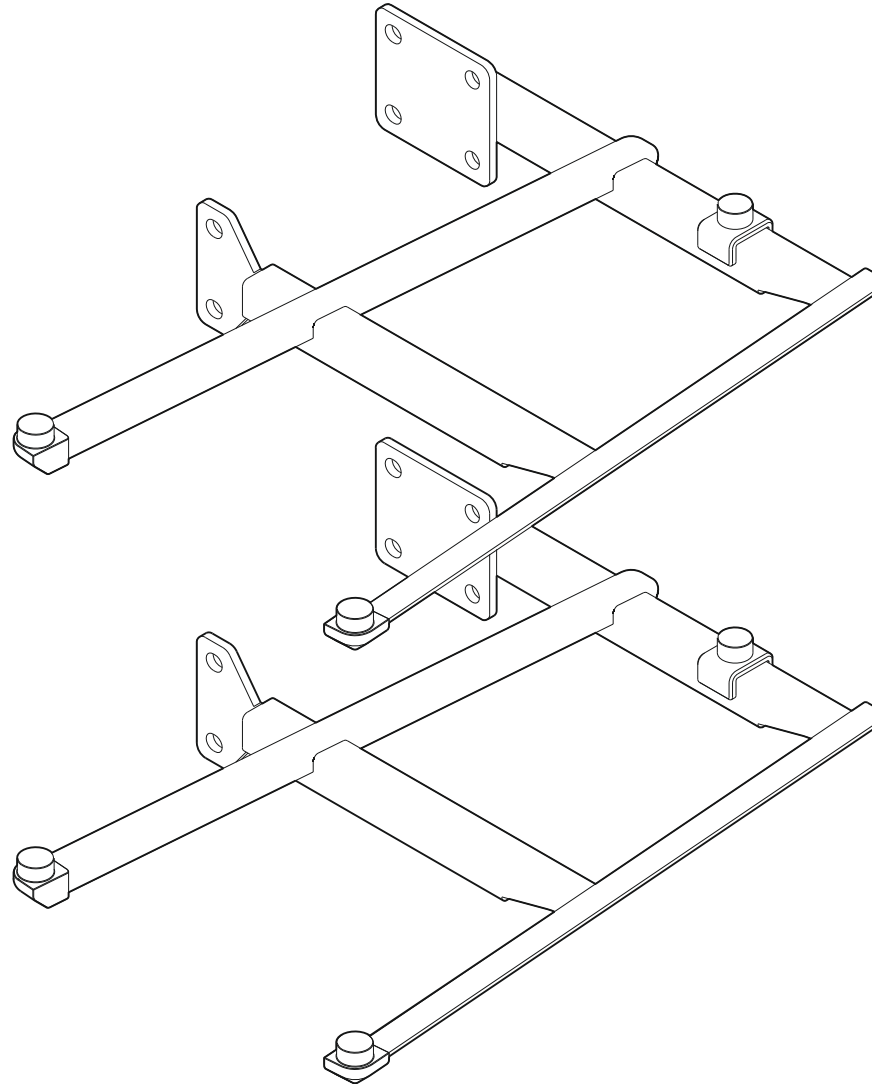

HARK III

3S-HARK3/SH - HARK III SHELF KIT

CAUTION!

- Before unpacking the stand clear a working space to assemble it away from children and pets.
- Assembly should be undertaken by two people. Before assembly, plan the location of the stand in a place where the stand and cables to and from the system will not cause a hazard.
- The stand is mounted on adjustable floor spikes. Exercise caution when handling the sharp spikes and ensure feet, mains cables, equipment cables etc are not under the stand when placing the stand on a floor.
- The stand will be very heavy when loaded with Cyrus components. If necessary, use appropriate cups to protect flooring such as wood, vinyl or ceramic tiling that may be sensitive to the spike tips.
- The stand is designed only for floor mounting. Don't attempt to hang it on a wall.

CARE AND CLEANING

- Periodically check that the stand is level and that all fixings are firmly secured.
- Never clean any of the stand components with scourers, abrasive pads or chemicals.
- Clean only with a dry cloth. A soft paintbrush can be used to clean dust from less accessible parts of the stand.
- If possible, retain the original packaging in case the stand should need transport in the future.

SPECIFICATIONS

Construction	Steel
Weight	4.5kg (Un-laden)

WARRANTY

The warranty period is two years. No retailer or distributor may vary the terms of this warranty, which is personal to the original purchaser and is not transferable. Please retain the sales receipt as proof of purchase. Warranty claims must wherever possible be made through the retailer from whom the equipment was purchased.

This warranty excludes:

Damage caused through neglect, accident, misuse, wear and tear, or through incorrect installation, adjustment or repair by unauthorised personnel. Any unauthorised servicing will result in loss of warranty. Liability for damage or loss occurring in transit to or from the purchaser. Consequential damage, loss or injury, arising from or in conjunction with this equipment. Equipment for attention under warranty should be consigned return carriage paid. If returned equipment is found to comply with the published specification, CYRUS reserves the right to raise a charge.

The above conditions do not affect your statutory rights as a consumer.

HINTS AND TIPS TO IMPROVE YOUR LISTENING EXPERIENCE

- The stand is supplied with all tools necessary for assembly. A spirit level may also be useful, also a torch and small mirror to see behind the Cyrus components when wiring if the system is placed close to a wall.
- Only build the number of shelves you need for your system. Empty shelves will affect the quality of sound from the system.
- Make sure the stand is level in the location you planned before adding any Cyrus components. Take some time at the installation stage to level the base of the stand with a spirit level to ensure it doesn't rock in any direction. There is a small amount of levelling adjustment in the shelf fixings. These can be adjusted if necessary by slackening the fixings and using a spirit level.
- When placing a Cyrus component on a shelf it is advisable to cover the top and sides of the unit with a thick cloth or a small towel to protect against accidental damage to the component from the stand metalwork.
- Make sure the Cyrus components are aligned correctly on the Cyruthane supports. When correctly aligned the feet on the component should not touch the metal shelf.
- Avoid any noise and rattles from cables in and around the stand. Once the system is wired fix all cables inside the spine of the stand to the securing plates. Use tie-wraps to tie loose cabling together.

ENJOY YOUR CYRUS PRODUCTS!

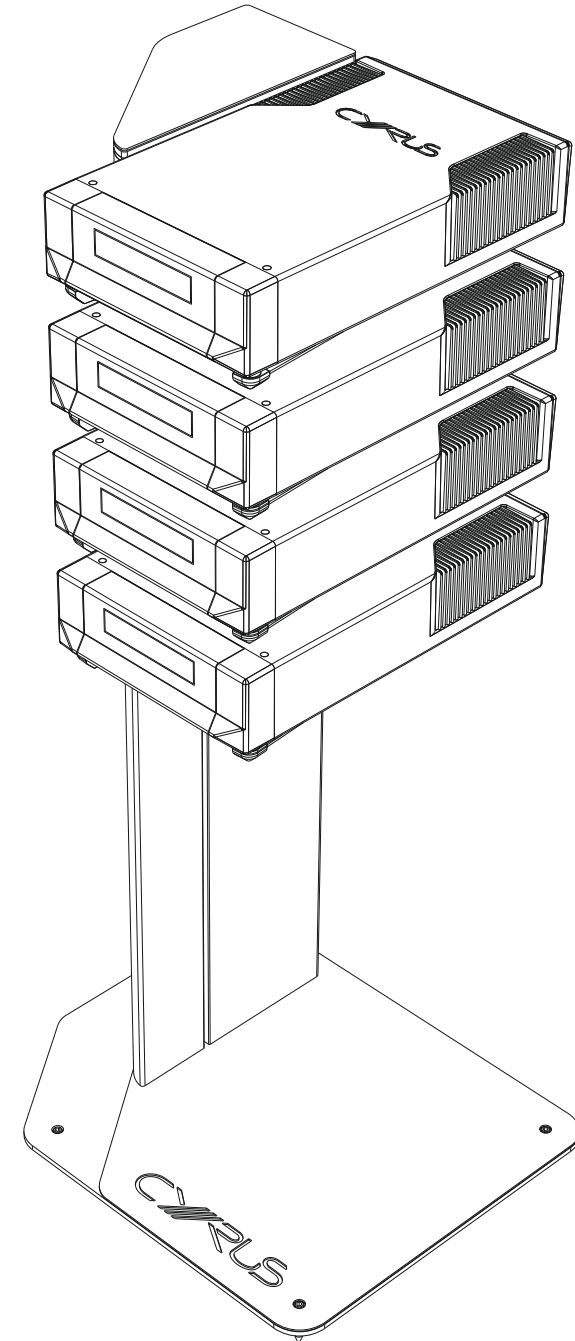

HARK III

3S-HARK3/SH - HARK III SHELF KIT

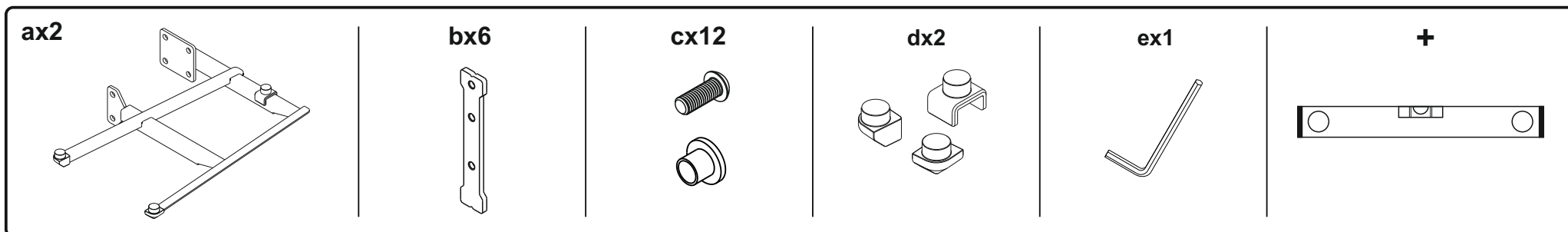

2a

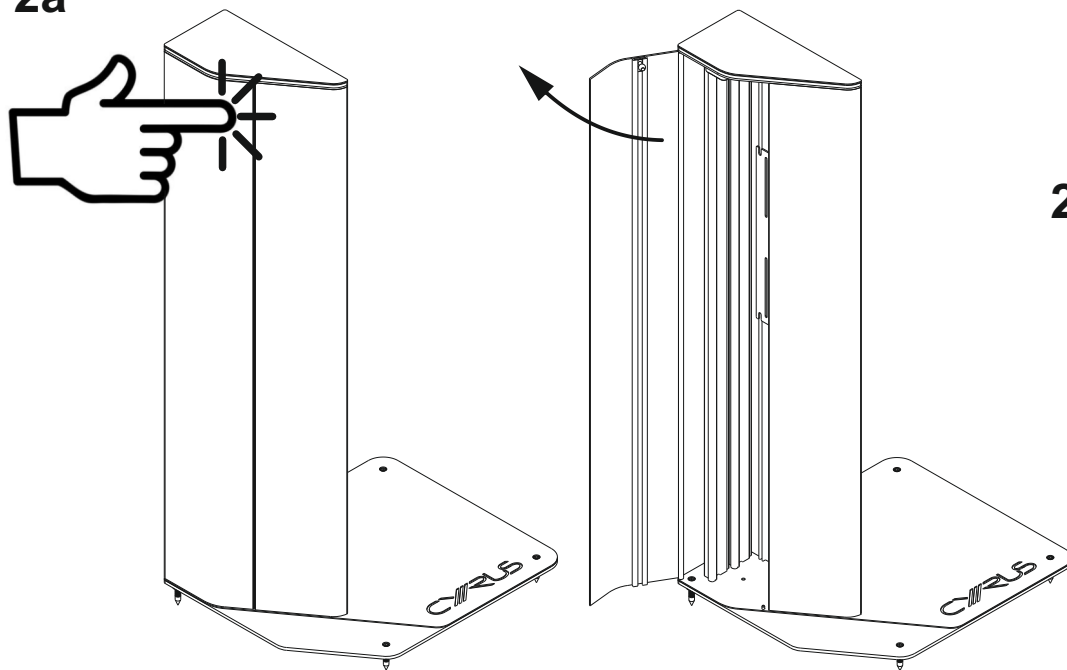

2b

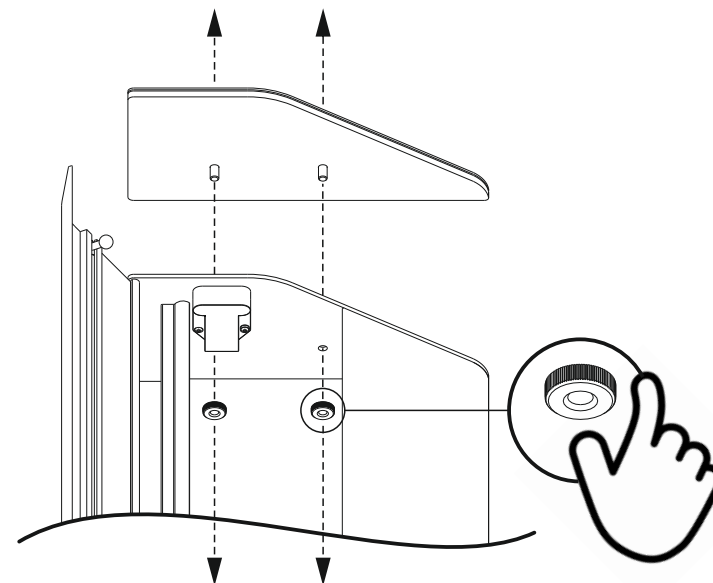

3a

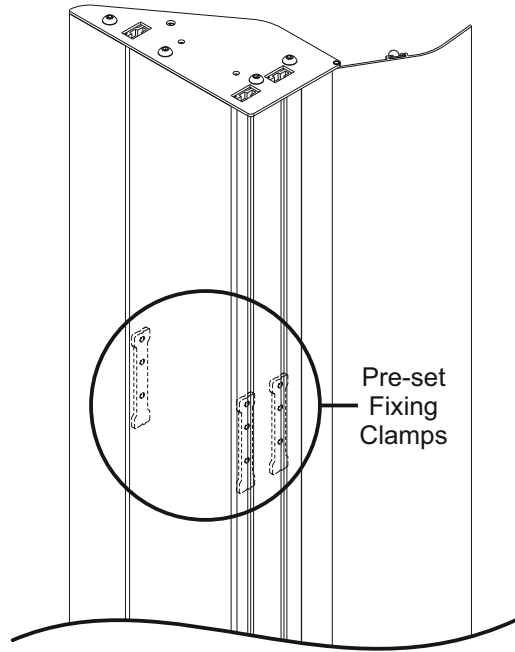

Pre-set
Fixing
Clamps

3b

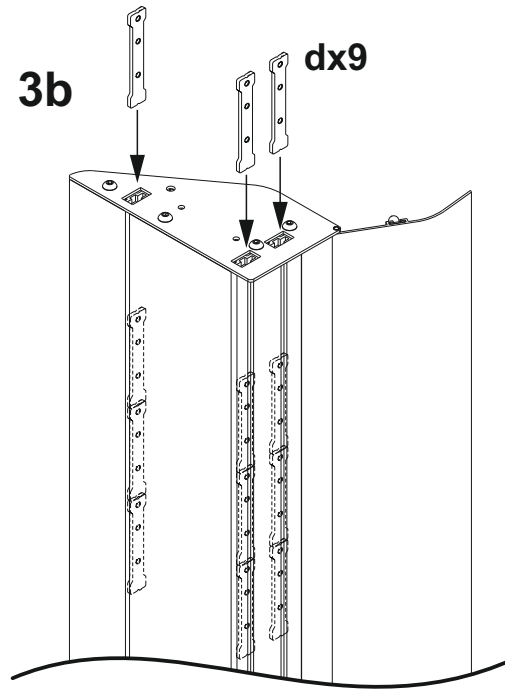

dx9

3c

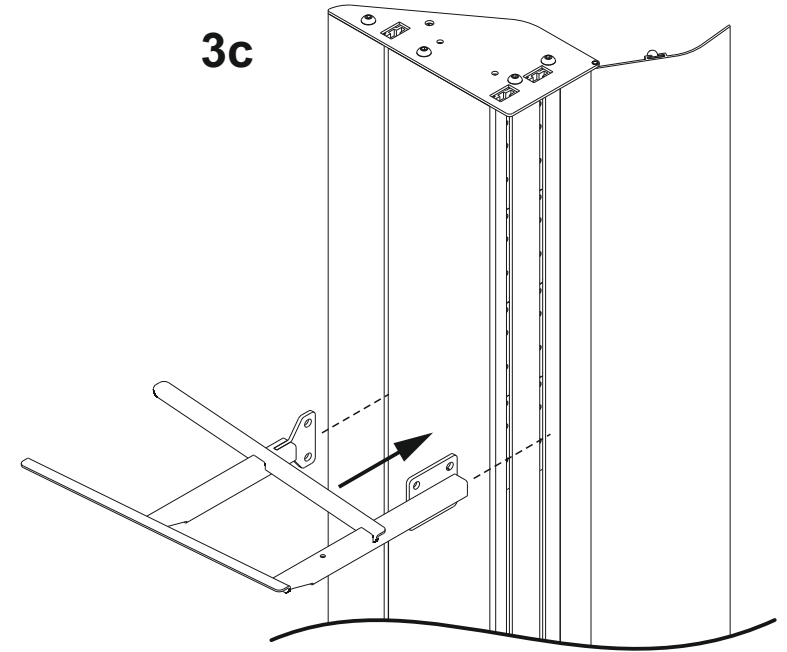

3d

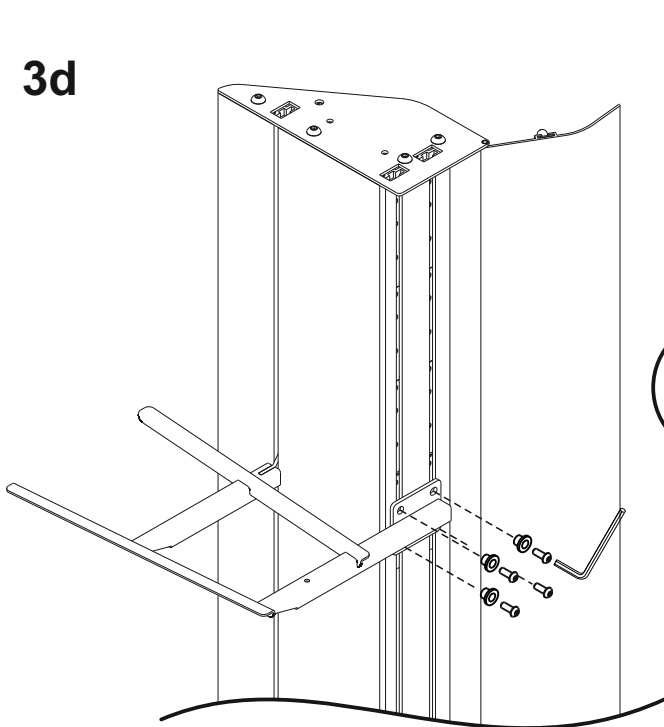

ex24

3e

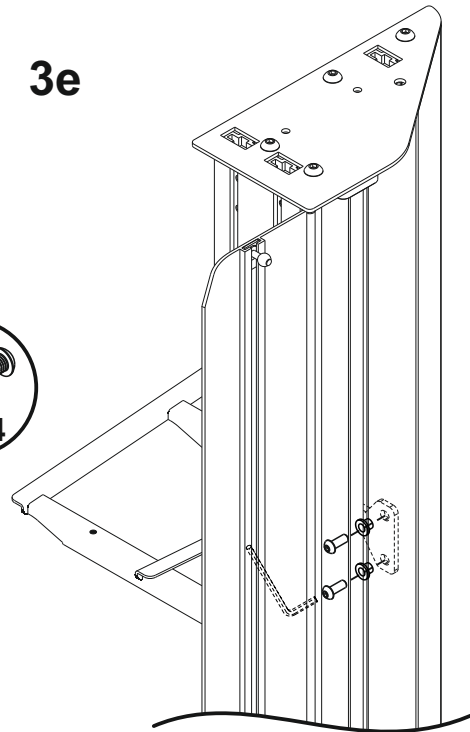

3f

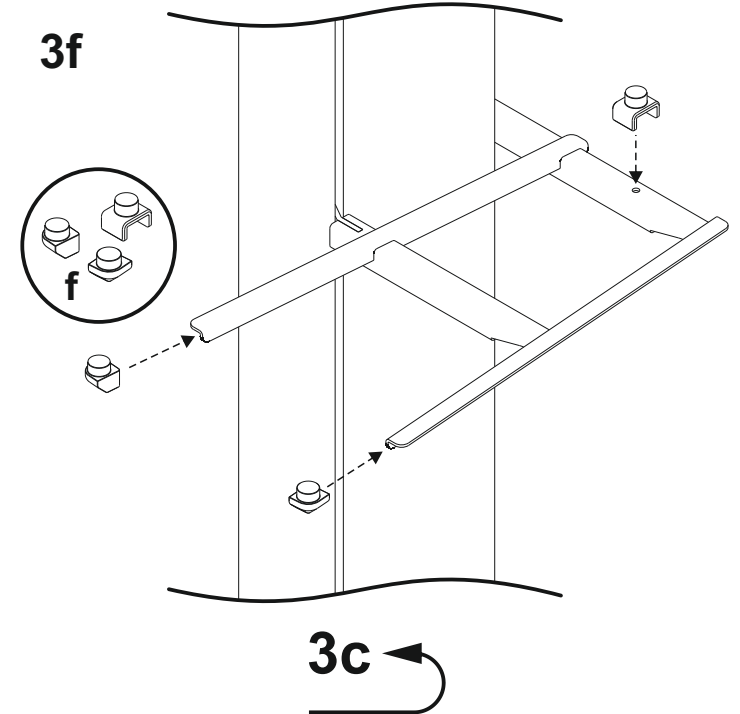

3c

4a

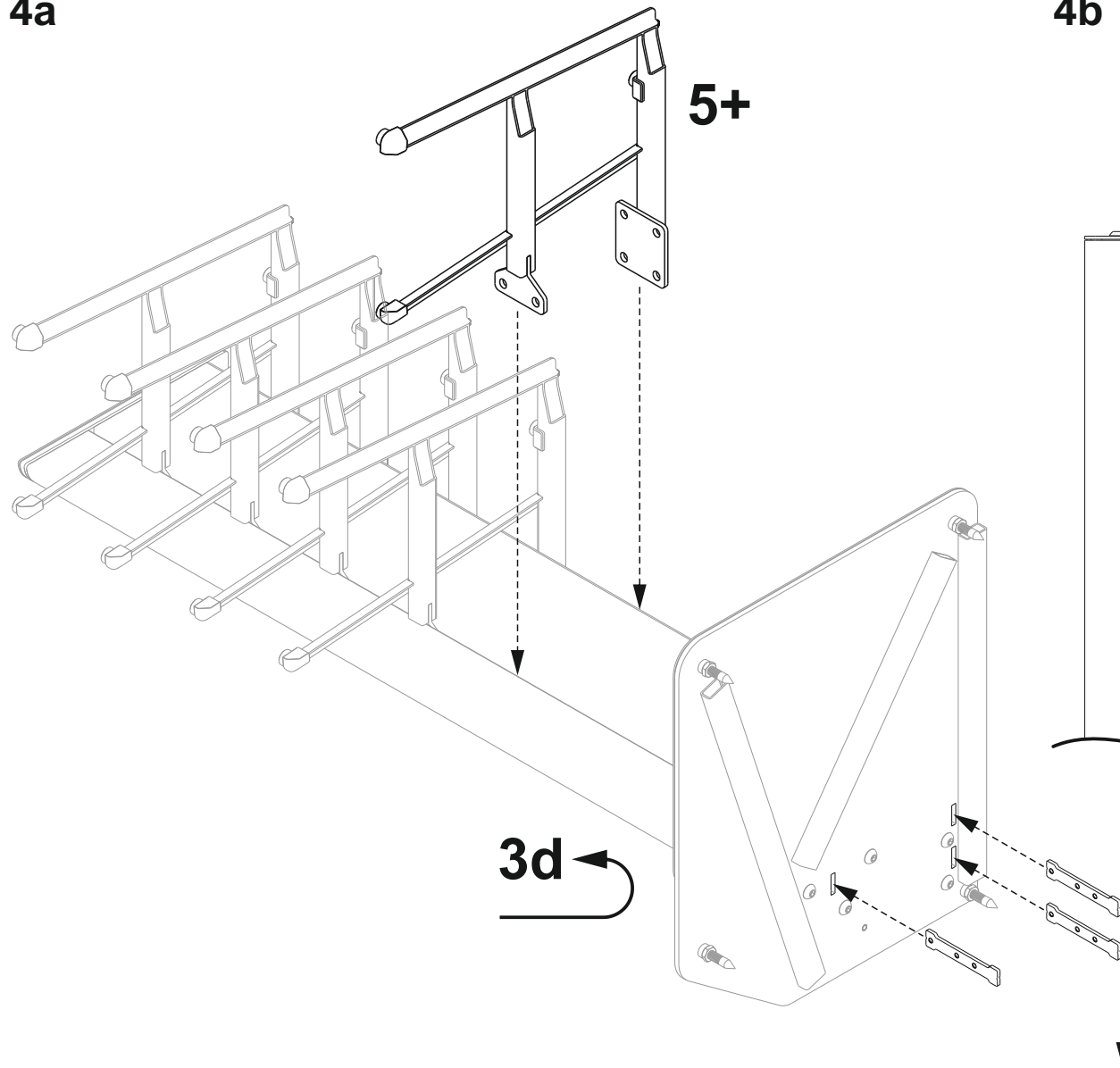

4b

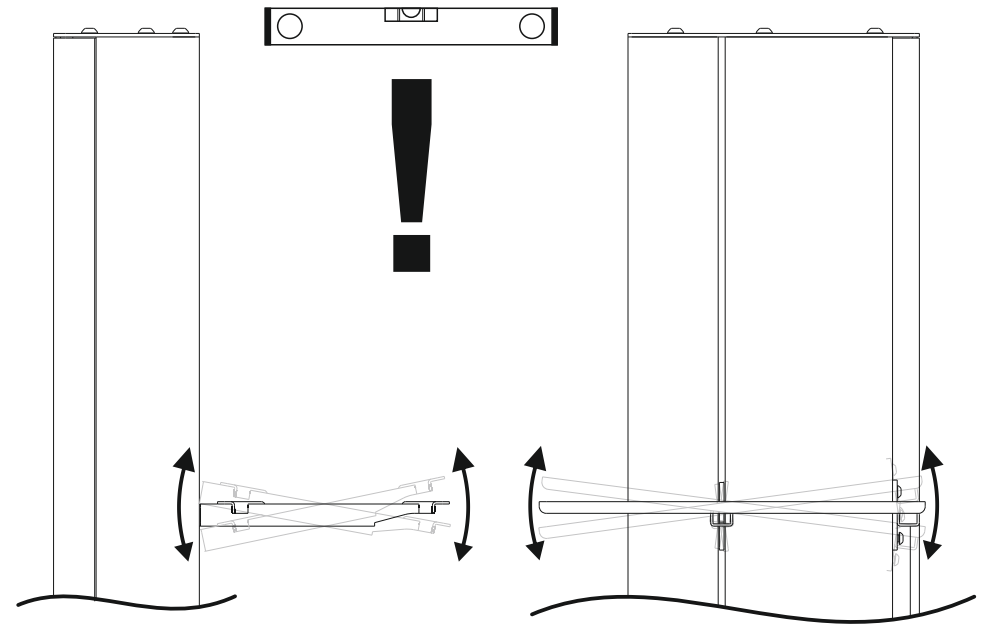

5a

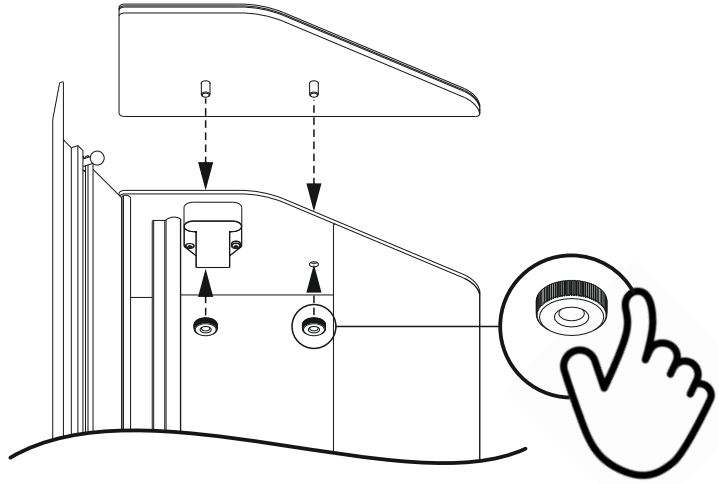

5b

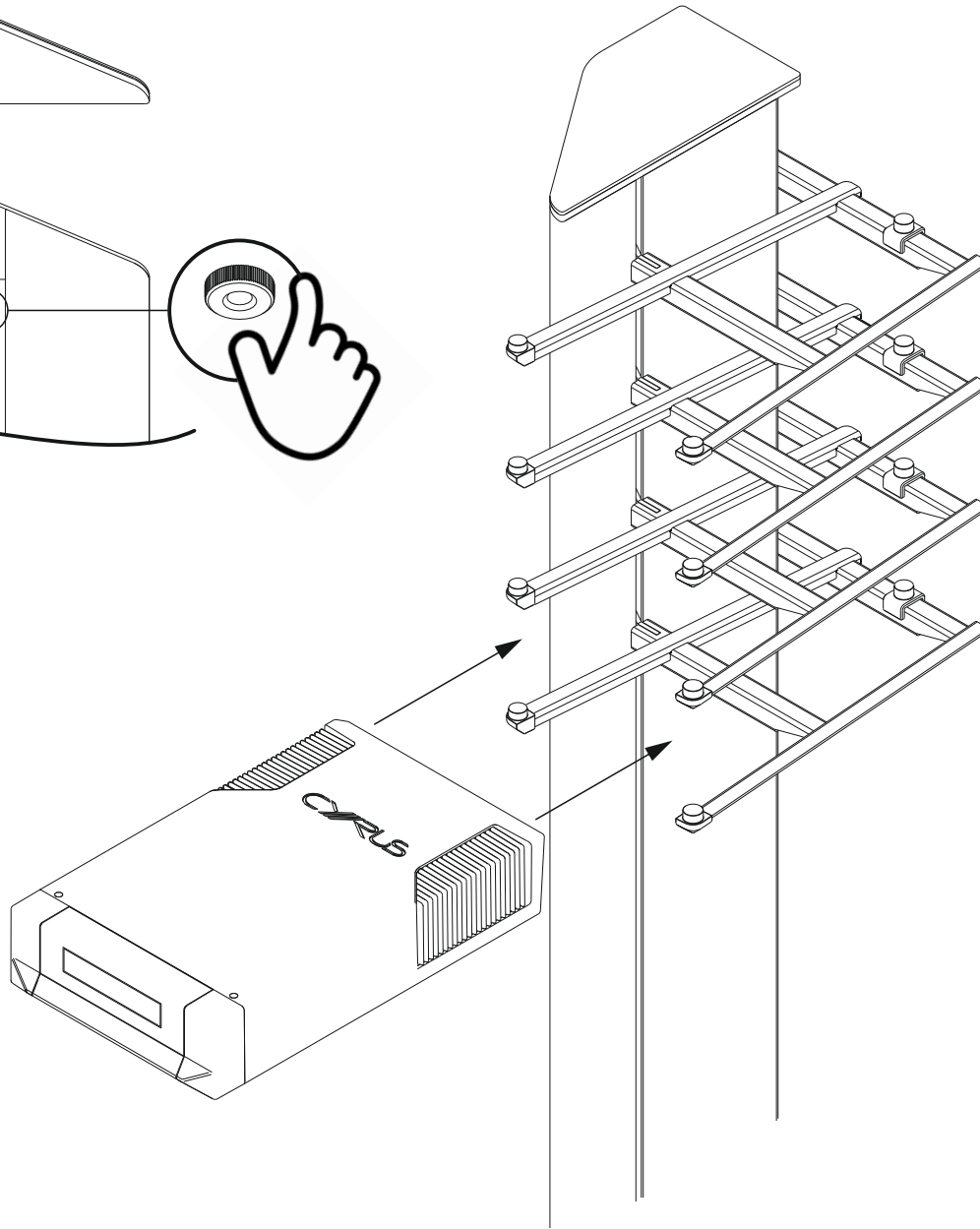

5c

